

DATA SHEET

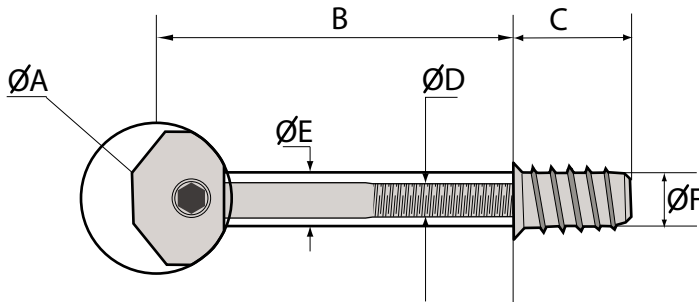

QT 12.720 90mm x 6mm Mini KD Connector

SPECIFICATION



SHAFT CENTRE CALCULATION

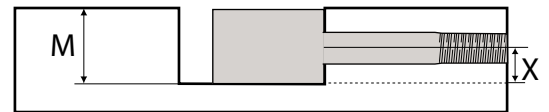

M= Minimum Bore Depth 12.5mm (31/64 inches)
X = Shaft Centre 5.5mm (13/64 inches)

Measurements

Millimetres	Inches
25	1
50-60	1 ³¹ / ₃₂ - 2 ²³ / ₆₄
21	⁵³ / ₆₄
6	¹⁵ / ₆₄
7	⁹ / ₃₂
10	²⁵ / ₆₄



A variation of bore size of 10.5-11mm for Insert Screw (F) may be required for hardwoods or when drilling into end grain. Use waxing or lubrication if required to level Insert Screw flush in the material. If required countersink hole to ensure Insert Screw is flush or below surface level of material.